

C-Bus® Light Level Detector,
Surface Mount



5754PE

The 5754PE light level detector is a C-Bus input unit that measures the ambient light level and converts the information into messages that are sent across the C-Bus network.

Ambient light levels are compared to the user-defined target light level. Control messages are then sent to output units to alter the lighting levels as required.

The detector readily mounts on solid surfaces such as masonry or wood. A single twisted pair connection provides both the C-Bus network interface and power for the detector.

- Quickly mounts on solid surfaces such as masonry or wood
- Extends only 33mm from the mounting surface
- Ambient light level measurement range from 0–2000 lux
- Programmed using C-Bus Toolkit software
- Light level threshold value is set in software
- Trimpot controls on the unit set the light level adjustment and the light level threshold
- SELV/Class 2 device. Powered from the C-Bus network. Requires no connection to building power
- LED indicators show when light level monitoring is active and when the assigned C-Bus group is active
- Removable connectors allow for daisy chain wiring. The unit can be placed anywhere on the C-Bus network

- Software provides selectable group addressing for the light level target
- Selectable group address for the light level margin
- Selectable block for which the High/Low thresholds are controlled by a group
- Selectable group address for High/Low lux levels
- Bank switching of lighting levels based upon the Light Level Set Point
- Daylight harvesting to maintain a constant user-configured light level

5754PE C-Bus Light Level Detector, Surface Mount

Ordering Information

Catalogue Number	Description
5754PE	C-Bus light level detector, surface mount

Specifications

Parameter	Description
Supply voltage	15 - 36V d.c. supplied by C-Bus network. Does not supply power to the network.
Current requirement	15mA
Light level sensor range	0 to 2000 lux
Controls	Trimpot A: light level adjustment Trimpot B: light level threshold adjustment
Indicator LEDs	Red LED: light level maintenance is active Orange LED: assigned network group is active
Ambient operating temperature range	5° to 50° C
Ambient operating humidity range	10 to 90% RH (non-condensing)
Standards tested to	AS/NZS CISPR 22 IEC CISPR 22 and CISPR 24 EN55022 and EN 55024 RoHS
Warranty	Two-year warranty against manufacturing defects.

Dimensions

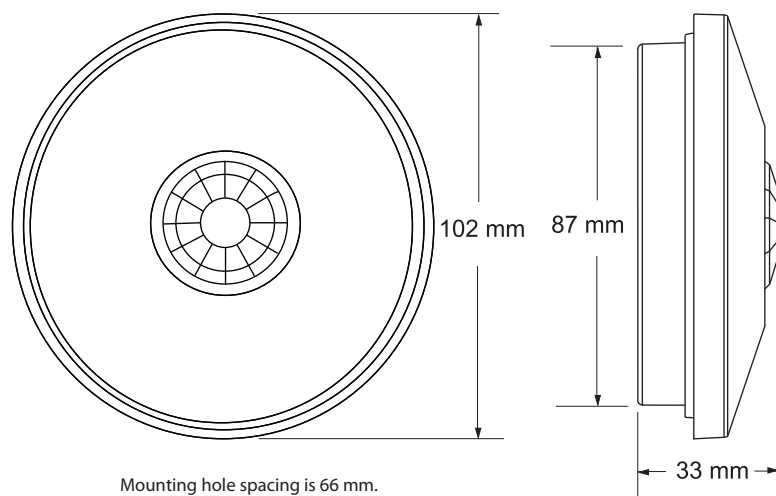

Clipsal Australia Pty Ltd

A member of Schneider Electric

Head Office

33-37 Port Wakefield Road,
Gepps Cross, South Australia 5094

PO Box 132, Enfield Plaza
South Australia 5085

clipsal.com/cis

Internet: <http://clipsal.com/cis/>
E-mail: cis.support@clipsal.com.au

Contact us at:

<http://www.clipsal.com/feedback>

International Sales and Marketing

E-mail: export@clipsal.com.au

You can find this data sheet and many others online in PDF format at: clipsal.com

The information in this data sheet is provided in good faith. Schneider Electric has endeavoured to ensure the relevance and accuracy of the information. It assumes no responsibility for any loss incurred as a result of its use.