



# DDLEDC605GL

PWM Controller

Directly drive LED fittings with PWM voltage-mode outputs

The Philips Dynalite DDLEDC605GL is designed to control LED loads in decorative architectural lighting applications where creative color mixing and sequencing is required. The controller provides six PWM common-anode voltage-mode outputs, suitable for directly driving high-intensity LED sources. The controller is designed for connection to an external DC power supply, enabling the unit to deliver a range of nominal output voltages. This controller is DMX512 compatible and is suitable for the high chase speeds commonly found in display lighting.

# DDLEDC605GL

## Directly drive LED fittings with PWM voltage-mode outputs

- **Designed for connection to external power supply** – The device is connected to an external DC power supply, enabling the unit to deliver a range of nominal output voltages.
- **Single or Dual External DC Supply** – Dual DC supply option overcomes single DIN rail power supply limitations and allows dual voltage load control between groups 1-3 and 4-6.
- **DMX512 compatible** – Capable of receiving native DMX512, allowing use in color mixing or chase sequence applications, such as those found in display lighting.
- **Diagnostic functionality** – Device Online/Offline status reporting.
- **Flexible mounting solution** – A DIN rail mountable device, designed to be installed into a distribution board or other electrical enclosure.
- **Naturally ventilated** – Requires no forced cooling or maintenance.

---

## Dimensions

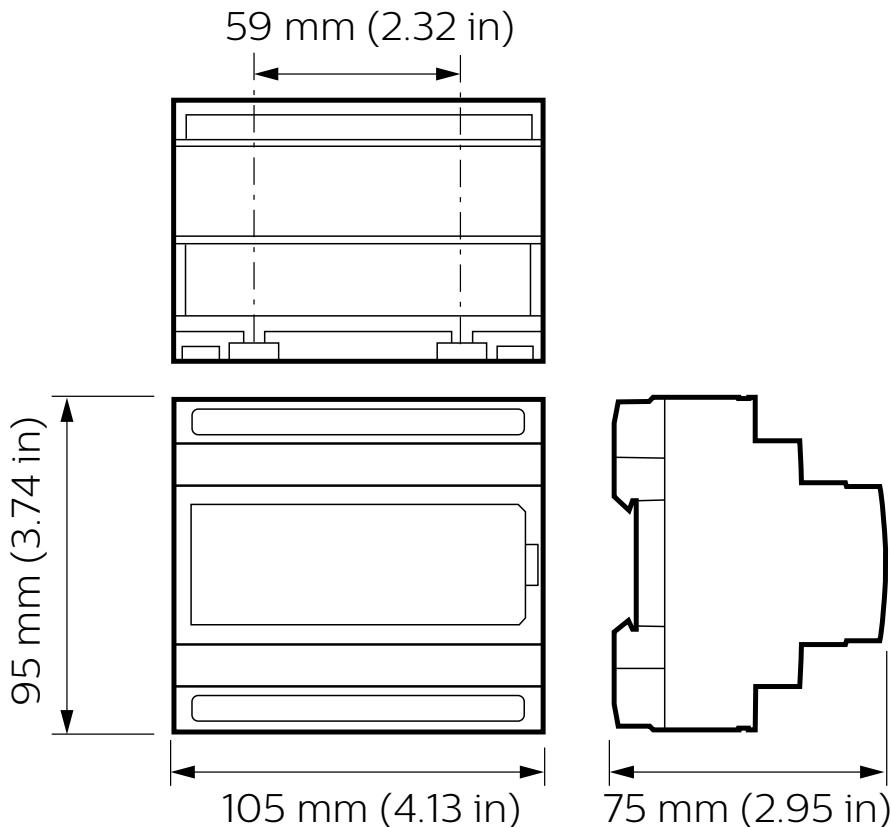

# Specifications

Due to continuous improvements and innovations, specifications may change without notice.



**DDLEDC605GL**  
PWM Controller

## Electrical

Supply Type	DC (regulated external SELV / Class1 or Class 2* supply)
Supply Voltage	10-24 VDC
Supply Current	20 A
Outputs	6 x LED PWM
Output Channel Voltage	10-24 VDC (minus internal voltage drop of 0.25-0.5 V)
Output Channel Current	10 mA to 5 A
Maximum Device Load	20 A
DyNet DC Output Voltage	12 VDC
DyNet DC Output Current	120 mA (supply for approximately 6 user interfaces)
Electrical Protection	Thermal overload protection Short circuit protection
IEC Overvoltage Category	III

## Control

Serial Ports	1 x RS485
Supported Protocols	DyNet DMX512 Rx
DMX Rx Channels	6
Dry Contact Inputs	1 (AUX)
Diagnostic Functions	Device online/offline status
User Controls	1 x service switch 8 x DMX start address DIP switch
Indicators	1 x service LED

## Physical

Dimensions (H x W x D)	95 x 105 x 75 mm (3.74 x 4.13 x 2.95 in)
Packed Weight	1 kg (2.2 lb)
Construction	Polycarbonate DIN rail enclosure (6 unit)
Serial Ports	1 x RJ12 1 x 6-way screw terminal
Serial Port Conductor Size	2.5 mm <sup>2</sup> (#12 AWG) (max)
Supply Terminals	3 x screw terminal (+Ve1, +Ve2, -COM)
Supply Terminal Conductor Size	2.5-4 mm <sup>2</sup> (#12-11 AWG) (max)
Load Terminals	12 x screw terminal
Load Terminal Conductor Size	2.5 mm <sup>2</sup> (#12 AWG) (max)

## Environment

Operating Temperature	0° to 40°C ambient (32° to 104°F)
Storage/Transport Temperature	-25° to 70°C ambient (-13° to 158°F)
Humidity	0 to 90% non-condensing
IEC Pollution Degree	II

## Compliance

Certification	CE, RCM, RoHS
---------------	---------------

\* See NFPA 70 (NEC) Article 225 and CSA 22.1 (CEC) Section 16 for Class 1 and Class 2 voltage and current limitations



# Electrical

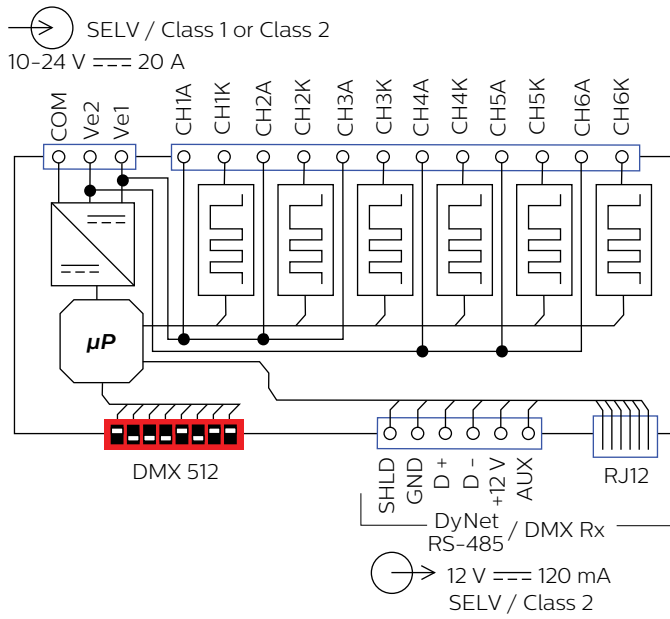

## Ordering Code

### Product

DDLEDC605GL

### Philips 12NC

913703061209

