

# DLLI8180

Dry Contact Interface

## Eight-way dry contact interface

The Philips Dynalite DLLI8180 is an eight-way dry contact interface with LED indicator outputs, that allows mechanical and electronic switches to communicate directly to the DyNet network.

# DLLI8180

## Eight-way dry contact interface

- **Compact size** – Allows installation in electrical wall boxes for easy integration with third-party user interfaces.
- **Eight dry contact inputs** – Each dry contact trigger is individually programmable for a range of tasks.
- **Eight indicator outputs** – Each output is individually programmable to drive an external LED indicator sharing a common cathode, communicating current system status or settings.
- **Allows up to 20 m cable runs** – Enables convenient connection to dry contact interfaces in multiple rooms.

---

## Dimensions

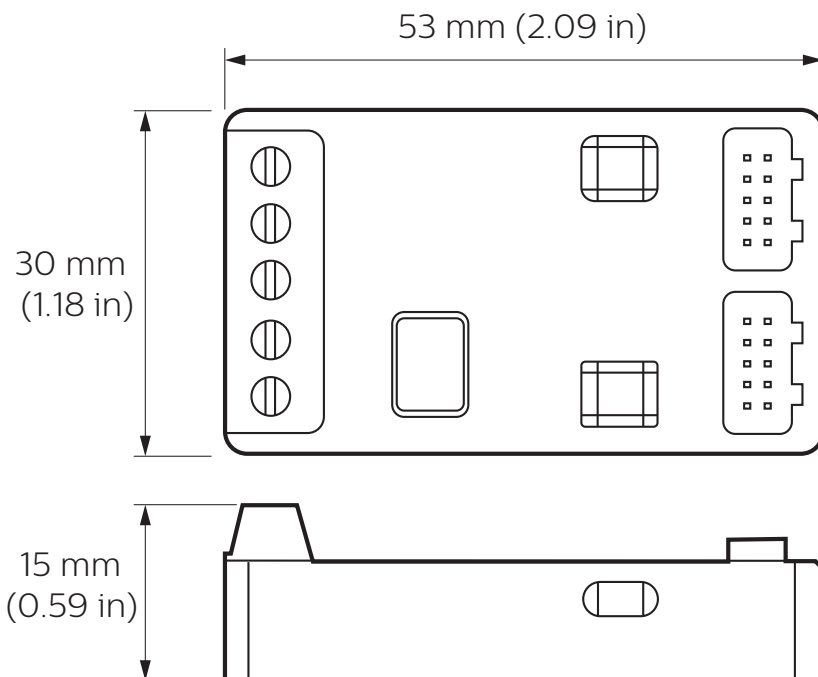

# Specifications

Due to continuous improvements and innovations, specifications may change without notice.



**DLLI8180**  
Dry Contact Interface

## Electrical

Supply Type	DyNet
Supply Voltage	12-24 VDC
DyNet Supply Current	30 mA
Dry Contact Open Switch Voltage	12 VDC (max)
Dry Contact Closed Switch Current	0.4 mA (max)
LED Output Channels	8
LED Output Channel Current	1.65 mA
IEC Overvoltage Category	III

## Control

Communication Ports	1 x RS-485
Supported Protocols	DyNet
Dry Contact Inputs	8
User Inputs	1 x service switch
Diagnostic Functions	Device online/offline status

## Physical

Dimensions (H x W x D)	53 x 30 x 15 mm (2.09 x 1.18 x 0.59 in)
Flylead Length	150 mm (5.91 in)
Packed Weight	50 g (0.11 lb)
Construction	Plastic housing
Communication Ports	5 x screw terminal
Communication Terminal Conductor Size	1.5 mm <sup>2</sup> (#16 AWG) (max)

## Environment

Operating Temperature	0° to 40°C ambient (32° to 104°F)
Storage/Transport Temperature	-25° to 70°C ambient (-13° to 158°F)
Relative Humidity	0 to 90% non-condensing
IEC Pollution Degree	II

## Compliance

Certification	CE, RCM, UL/cUL, FCC, ICES, RoHS
---------------	----------------------------------



# Electrical

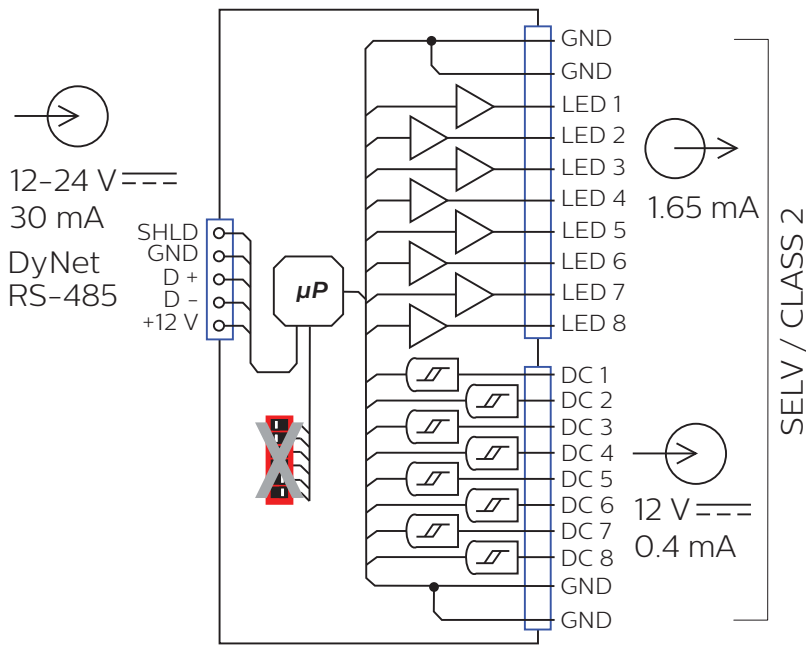

## Ordering Code

**Product**  
DLLI8180

**Philips 12NC**  
913703023009



© 2018 Signify Holding. All rights reserved. Specifications are subject to change without notice. No representation or warranty as to the accuracy or completeness of the information included herein is given and any liability for any action in reliance thereon is disclaimed. Philips and the Philips Shield Emblem are registered trademarks of Koninklijke Philips N.V. All other trademarks are owned by Signify Holding or their respective owners.